



RF MORECOM
COREA

New Technology for mmWave Antenna with FEM Application

Technology Innovation of RF Microwave Industry



• Contents

1. RF Lens-Embedded mmWave Antenna Array with smallest FEM embedded.
2. ADK360° antenna for 5G NR Test
3. AoD antenna for 5G NR UE
4. SPA FEM Module for mmWave CPE and IoT, etc.
5. P360° 16: 4 × 4 Antenna-FEM module for mmWave CPE and IoT, etc.
6. P360° 16S: 4 × 4 Antenna-FEM module for mmWave CPE and IoT, etc.

1. RF Lens-Embedded mmWave Antenna Array

Strong points for RF Lens-Embedded mmWave Antenna Array

- **Features**

- Small Size (more than 50% , Compared to conventional antennas)

- Robust Data Link Connection (Beam width , vibration, Fading ..)

- Easy installation for link antenna adjustment (Auto Beam Tilting)

- **Application**

- Point to point data link

- Massive MIMO mmWave 5G NR front module

- 5G private data service

- 5G NR IAB

1. RF Lens-Embedded mmWave Antenna Array

Current Antenna Solution

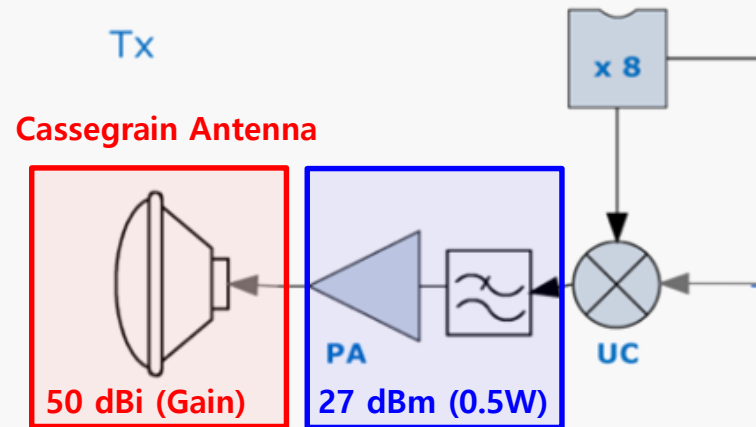

Summary

EIRP: 77 dBi
 HPBW: 0.8 deg
 Diameter: > 70 cm

Proposal (Ant + FEM embedded at back side)

Lens + 1024-element phased-arrays + 64 RFFE ICs

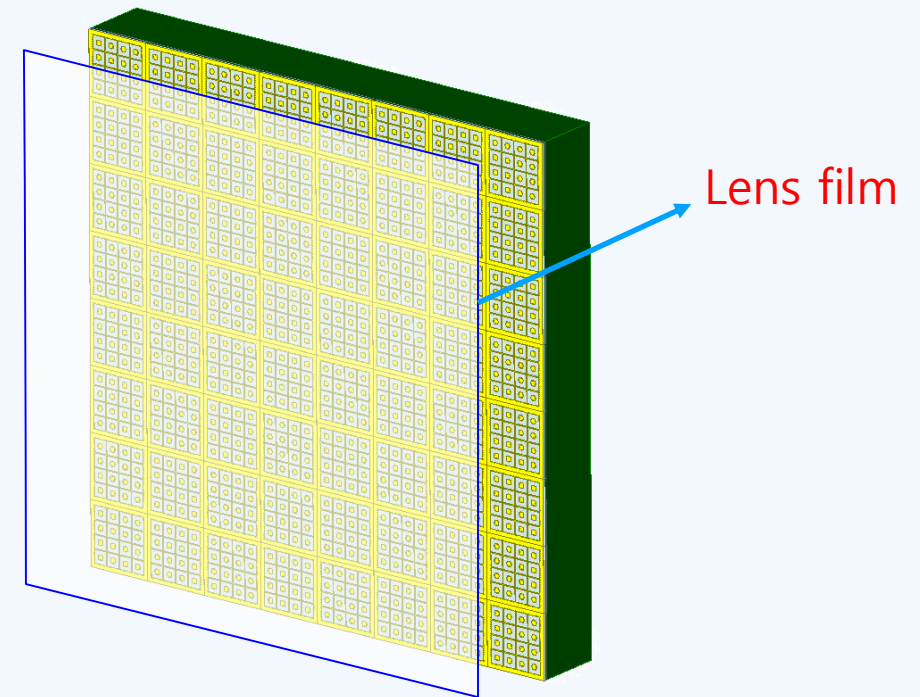

Summary

EIRP: 80 dBi
 HPBW: 3 deg
 Diameter: < 30 cm
 Power consumption: 12.8 W
 Identical RF port interface

1. RF Lens-Embedded mmWave Antenna Array

Current Antenna Solution

Data link connection
(Alignment)

1km

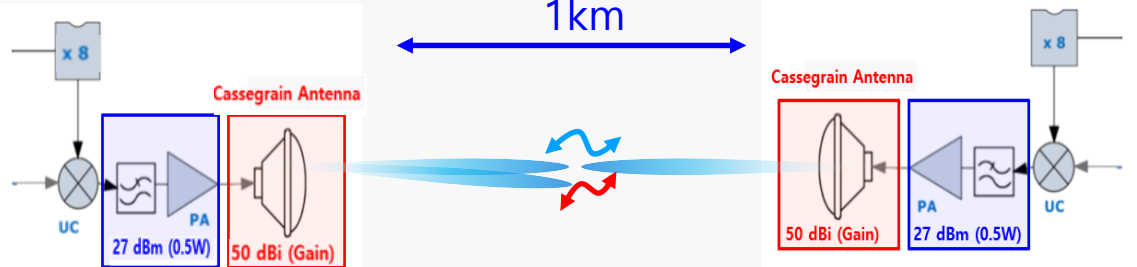

Susceptible to Data link
disconnection
due to Misalignment)

EIRP: 77 dBm
HPBW: 0.8 deg
Diameter: > 70 cm

Proposal Antenna Solution Robust Data Link Connection

Data link connection
(Alignment)

1km

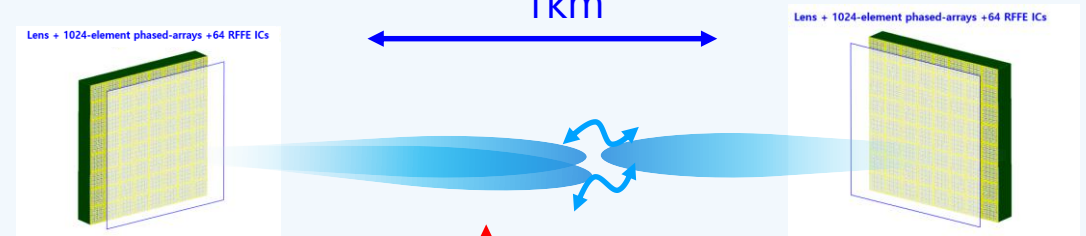

★
Robust to unpredicted
Antenna misalignment
(4X improvement)

EIRP: 77 dBm
HPBW: 3 deg
Diameter: < 30 cm
Power consumption: 12.8 W
Identical RF interface

1. RF Lens-Embedded mmWave Antenna Array

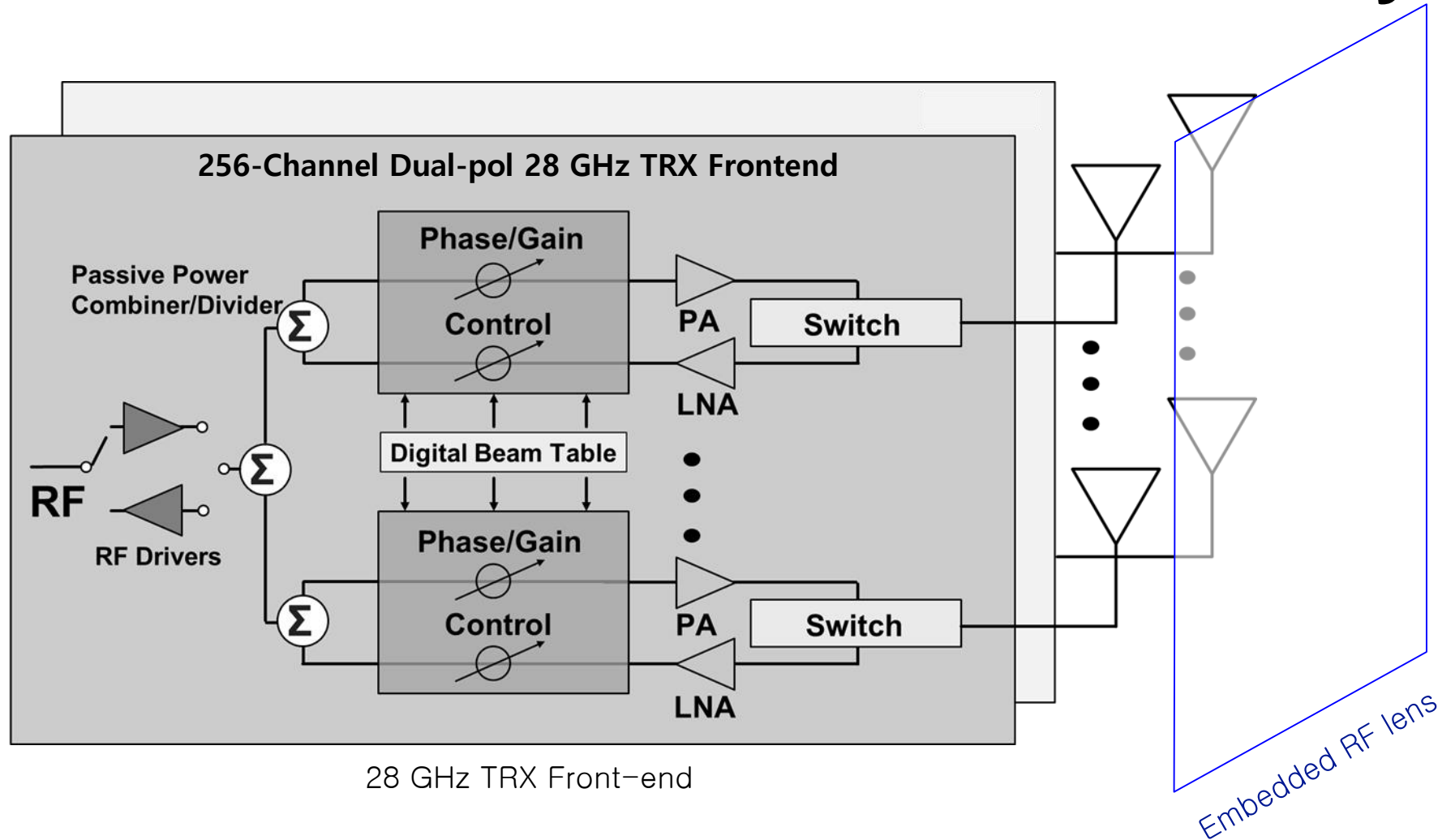

Key Features

- Operating Frequency : 26.5 – 29.5 GHz
- No. RF ports: 256 electronically controllable RF channels
- No. Antennas: 1024 for highly directive beamforming
- Total output power: 38 dBm (RF power) + 39 dBi (Phased array + RF lens + including related RF insertion loss)

2. ADK360°

Antenna Development Kit (ADK) for Ka-band mmWave 360° Beamforming Phase Array System.

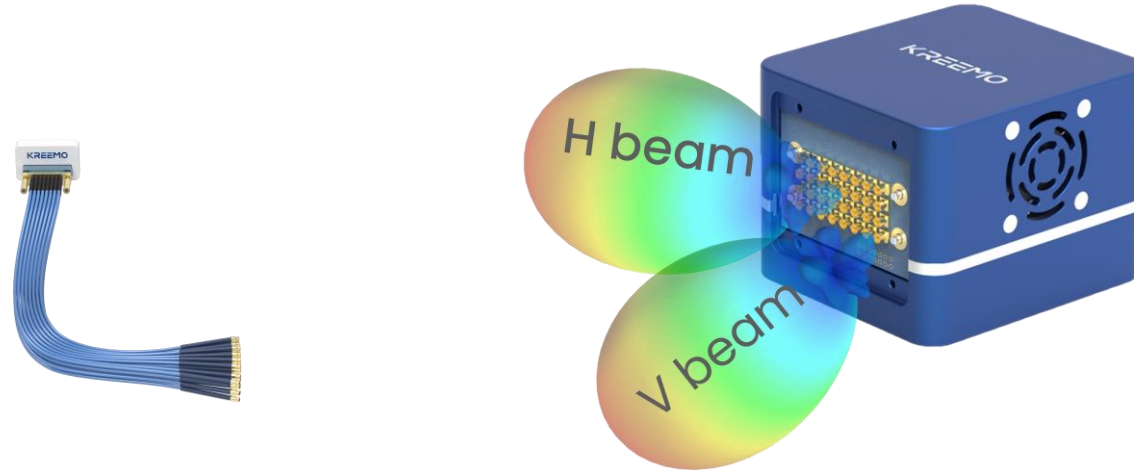

Overview

The Ka-band mmWave phased-array antenna development kit – ADK360° featuring dual-polarization and 32 electronically controllable RF channels. The ADK360° can efficiently emulate 5G mmWave RF front-end which can satisfy the 5G specification from the Third-Generation Partnership Project (3GPP). This new class of ADK360° includes ADK RF module featuring 32 TRX RF ports, power cable, and PC software. The overall size of the ADK RF module is 98 mm x 88 mm x 73 mm. In addition, we provide 1 x 4 SPA prototype which can radiate in three orthogonal directions, which are normal and parallel to the antenna prototype.

The magnitude and phase of each RF channel for ADK360° can be controlled wirelessly by using the BLE 5.0 interface.

2. ADK360°

Antenna Development Kit (ADK) for Ka-band mmWave 360° Beamforming Phase Array System.

Feature

- Operating Frequency : 26.5 – 29.5 GHz (5G NR FR2 n257)
- No. of RF ports: 32 electronically controllable RF channels (Support 16 Dual-Polarization Antennas)
- 11.25 deg-step 360°-range phase shifting per path
- 0.5 dB-step 15 dB-range Variable Gain per path
- 20 dB Common Gain Control
- GUI software to control RF channels
- Now Available !

Parts List of ADK360°

No	Parts Name	Description
1	ADK RF Module	32 Channel, Dual-pol Beamforming Evaluation Tool
2	WMX Cable	16 Ch. Multi coaxial Cable Assemblies
3	1 x 4 SPA	Antenna Prototype
4	USB Dongle	BLE USB Dongle
5	Power Cable	220V to 5V Power Supply Cable

3. AoD Module

Phased-array Antenna-on-Display (AoD) to Enhance Spherical Beamforming Coverage .



<Antenna-On-Display Film>



<Antenna-On-Display Module>

Overview

Antenna-on-Display (AoD) module has been developed to enhance foreside beamforming coverage for mmWave applications. The AoD module features display-integrated invisible antenna elements, a 5G mmWave beamformer IC with single RF I/O channels, and digital board with SPI interfaces. The module is designed using LTCC and SMT technology. By controlling the magnitude and phase of each RF ports, the AoD module can radiate in foreside direction, which are normal to the display panel. Near-isotropic beamforming coverage can be achieved by collectively integrating both AoD and antenna-in-package (AiP) solutions, resulting in maximizing the cumulative distribution function (CDF) beam coverage specified by the Third-Generation Partnership Project (3GPP).

3. AoD Module

Phased-array Antenna-on-Display (AoD) to Enhance Spherical Beamforming Coverage .

Feature

- Operating Frequency : 26.5 – 29.5 GHz (5G NR FR2 n257)
- No. of Pol: Two (dual-polarizations)
- No. of Antennas: 4 M-shaped antennas (8 RF channels)
- Realized Gain: > 7 dBi
- Thickness of AoD film: Less than 50 μm
- Now Available !

Parts List of AoD

No	Parts Name	Description
1	AoD Component	OLED display component with optically invisible antennas
2	AoD Module	8 RF Channel Beamformer Module
3	Digital/Power Board	Board to control BFIC and supply power
4	USB Dongle	BLE USB Dongle
5	Power Cable	220V to 5V Power Supply Cable



4. Stackable Patch Antenna with FEM as one set

mmWave 360° Beamforming Applications

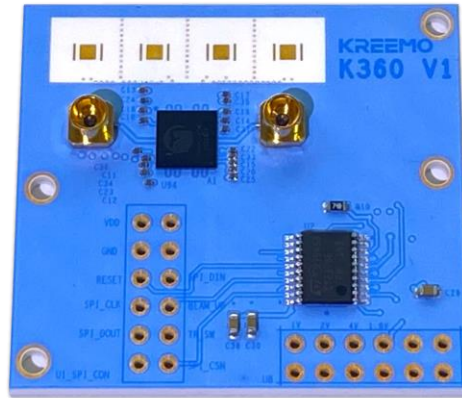

< P360° : 1x4 Stackable Patch Antenna Module >

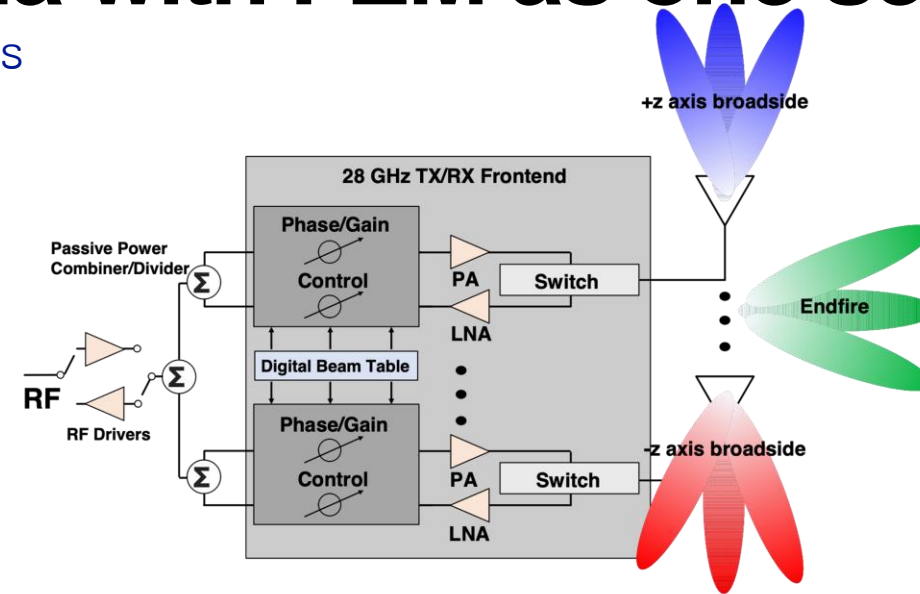

< Block diagram for SPA module >

Overview

stackable patch antenna (SPA) module has been developed to realize industry's first 360° beamsteering coverage across various mmWave products and applications. The antenna package for SPA module consists of eight single-polarized antenna elements and a 5G/SATCOM mmWave beamformer IC with single RF I/O channels and SPI interfaces. The antenna package is designed using PCB and SMT technology. The overall size of the SPA module is 40 mm x 35 mm x 2.2 mm. By separately controlling the magnitude and phase of each RF ports, the SPA module can radiate in three orthogonal directions, which are normal or parallel to the antenna package. Near-isotropic beamforming coverage can be achieved from SPA module by using the SPA1) technology, resulting in maximizing the cumulative distribution function (CDF) beam coverage specified by the Third-Generation Partnership Project (3GPP).

4. Stackable Patch Antenna with FEM as one set

mmWave 360° Beamforming Applications

Characterization

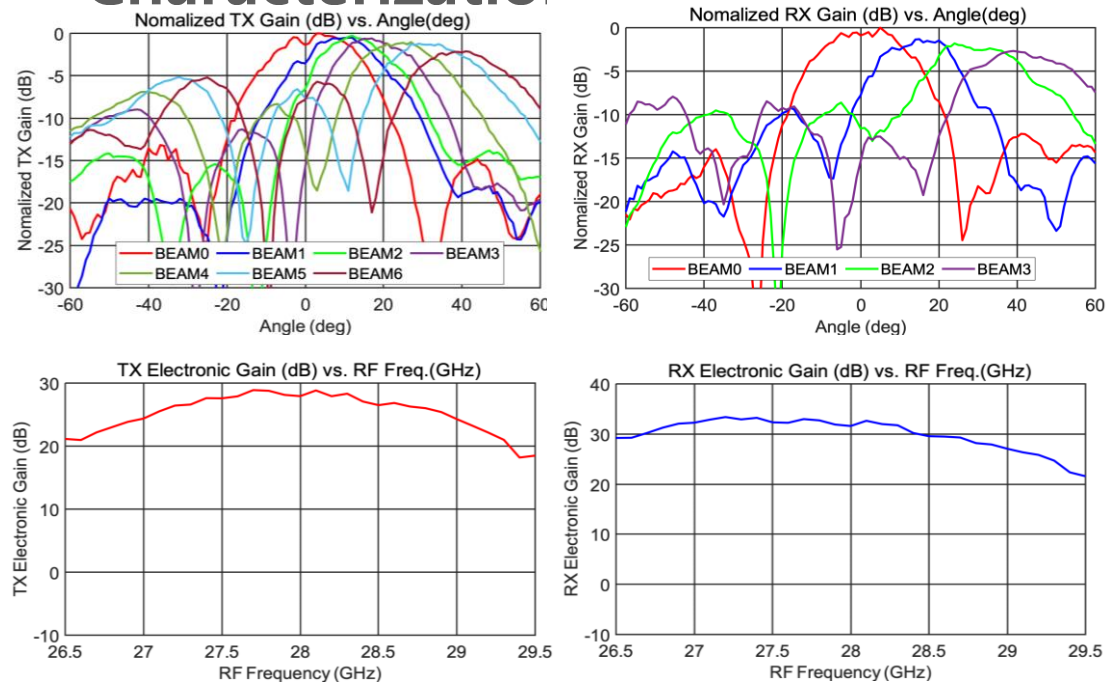

Spec.	Value
3dB Beamwidth in E-plane	97° (average)
3dB Beamwidth in H-plane	29° (average)
Broadside Gain at 28 GHz	9.5 dBi
Endfire Gain at 28 GHz	7.7 dBi
Impedance Bandwidth (S11 < -10 dB)	26.5 – 29.5 GHz
Radiation Efficiency (at 28 GHz)	85 %
TX Electronic Gain (Measured)	27.9 dB (28 GHz)
RX Electronic Gain (Measured)	31.6 dB (28 GHz)
Beam Steering Range in H-plane	± 40°

5. P360° 16: with FEM as one set

4 × 4 Antenna-in-Package (AiP)

Overview

P360° 16 containing
16 dual-polarized antenna topology
featuring wide beam scanning angles.

Characteristics

Operating Frequency : 26.5 – 29.5 GHz (5G NR FR2 n257)
(26.5 – 29.5 GHz)

No. of Pol: Two (Dual-polarizations)

No. of Antennas: 16 Antennas (32 RF channels)

Overall Size: 60 mm x 25 mm x 1.7 mm

11 Layers laminated by LTCC technology

EIRP > 28 dBm in the 5G NR FR2 band n257

Availability 22.4Q

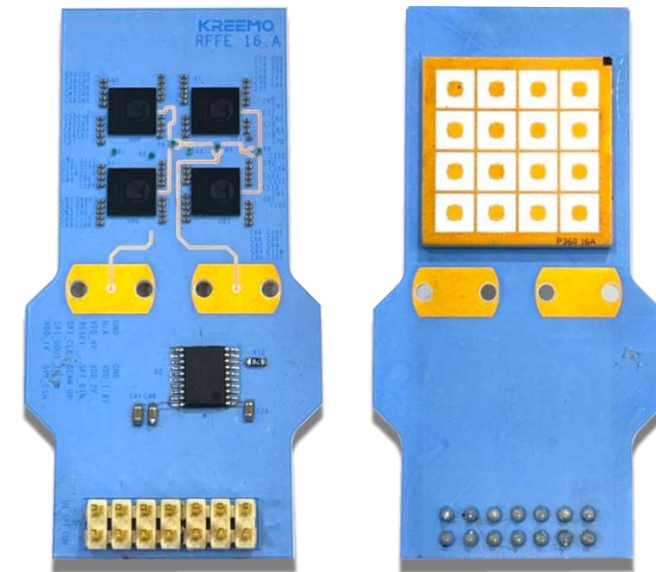

<P360° 16>

6. P360° 16 SPA with FEM as one set

4 × 4 Stackable patch antenna (SPA) Module

Overview

P360° 16 SPA containing two antenna package featuring 32 dual-polarized antenna topology with extremely wide beam coverage

Characteristics

- Two 4x4 Antennas are stacked at the top and bottom
- 360° Coverage
- Operating Frequency : 26.5 – 29.5 GHz (5G NR FR2 n257)
- Total 32 Antenna Elements
- Peak Gain 17dBi at 4x4 Antenna
- H-Pol and V-Pol
- VSWR <2
- Availability 23.2Q

